

Examination of the Predictive Validity of Preschool Early Literacy Skills

Kristen Missall
University of Kentucky

Amy Reschly
University of Georgia

Joseph Betts
Renaissance Learning, Inc.

Scott McConnell
Center for Early Education and Development, University of Minnesota

David Heistad, Mary Pickart, Christina Sheran, and Doug Marston
Minneapolis Public Schools

Abstract. The predictive validity of early literacy skills of children among preschool is relatively unknown. The purpose of this longitudinal study was to provide this examination. From a sample of preschoolers, longitudinal data were available for 143 of the children in kindergarten and for 116 of them through the end of first grade. Preschool children were assessed in the fall, winter, and spring with Early Literacy Individual Growth and Development Indicators (EL-IGDIs). In the fall, winter, and spring of kindergarten, literacy skills were assessed and curriculum-based measurement data in reading were collected in the spring of kindergarten and first grade. Results showed significant increases in mean EL-IGDI scores. In most instances, preschool administrations of the EL-IGDIs were moderately correlated with kindergarten measures of alphabetic principle and phonological awareness. Preschool EL-IGDIs were found to be significantly predictive of later outcomes in oral reading fluency both at the end of kindergarten and at the end of first grade. The diagnostic utility of these measures was found to be strong. Implications for practice are discussed.

This research was funded in part by the U.S. Department of Education, as part of the Minnesota Early Literacy Project (Grant S349A010152). The first three authors contributed equally to this article. This project was completed through a partnership between the Center for Early Education and Development at the University of Minnesota and the Research, Evaluation and Assessment Department of the Minneapolis Public Schools, Scott R. McConnell and David Heistad, Directors.

Correspondence regarding this article should be addressed to Kristen Missall, 235 Dickey Hall, University of Kentucky, Lexington, KY 40506-0017; e-mail: kristen.missall@uky.edu

Copyright 2007 by the National Association of School Psychologists, ISSN 0279-6015

In the past 15 years, reading achievement has been at the forefront of educational initiatives (e.g., Goals 2000: Educate America Act, 1994), debate (e.g., whole language vs. phonics, reading readiness vs. emergent literacy), and more recently, sweeping educational reform legislation (such as the No Child Left Behind Act of 2001). Although working to increase reading proficiency among our nation's school-age youth, it has become evident that the development of foundational literacy skills is critically important in the years before formal schooling. At the time of school entry, striking differences exist between young children in language and early literacy development, educational opportunities, and life experiences (National Assessment of Educational Progress, 1999; Shonkoff & Phillips, 2000; Snow, Burns, & Griffin, 1998).

Children who enter school behind their peers in language and early literacy development are unlikely to catch up (Fletcher & Lyon, 1998; Juel, 1988; Scarborough, 2002; Torgeson, 2002) and are at high risk for reading failure (Fey, Catts, & Larrivee, 1995; Stanovich, 1986; Whitehurst & Lonigan, 2002) as well as high school drop-out and broader social failure (National Center for Educational Statistics, 1992; Snow et al., 1998). Particular groups of young children are especially at risk for reading failure, including children with disabilities (Aram, Ekelman, & Nation, 1984; Bashir & Scavuzzo, 1992), children who live in poverty (Walker, Greenwood, Hart, & Carta, 1994), and children who speak a primary language other than English (August & Hakuta, 1997; Gutierrez-Clellan, 1999). Nevertheless, current educational practices in early elementary school generally allow children to proceed with reading-related tasks at their own rate. It is not until students have failed to acquire reading skills, and gaps between poor and proficient readers are large and often intractable, that formal intervention (e.g., Title 1 services, special education) is introduced. Yet, prediction about reading success can be made with very young children (Snow et al., 1998). In this era of increased accountability and escalating stakes, schools

and districts cannot afford to "wait" for students to fail. As such, there is increasing recognition that preschool education and early literacy development are imperative for improving later reading proficiency.

Development of Early Literacy Skills

Reading and early literacy are distinct but related concepts. Early literacy skills develop during the first 5 years of life and long before formal schooling when reading becomes the primary academic focus. Early skills, such as phonological awareness (e.g., rhyming, alliteration), vocabulary, letter naming, and word manipulation (e.g., word blending, word segmenting), are strongly related to the ability to use phonics later, and are precursory skills for learning to read successfully (Adams, 1990; Hart & Risley, 1995; Snow et al., 1998). In addition, early literacy skills, such as expressive and receptive language, understanding of concepts of print, linguistic awareness, letter-sound correspondence, emergent writing skills, and alphabetic principles, all contribute in varying degrees to reading development (Snow et al., 1998; for a complete discussion, see Whitehurst & Lonigan, 1998). Together, these skills build the foundation for reading. The earlier these foundational skills are acquired, the more efficiently and effectively additional skills can be learned.

Curriculum-Based Measurement Literacy Assessment

Based on almost 30 years' work, curriculum-based measurement (CBM) is an evidence-based approach to measuring student progress in core academic skill areas (Deno, 1985, 1997; Fuchs & Deno, 1991; Shinn, 1998). The years of research have culminated in substantial evidence for the reliability and validity of this approach, mostly within the area of reading (R-CBM; Ardoin et al., 2004; Baker & Good, 1995; Espin & Deno, 1995; Fuchs, Fuchs, & Maxwell, 1988; Hintze & Silberglitt, 2005; Hintze, Shapiro, Conte, & Basile, 1997; McGlinchey & Hixson, 2004; Shinn, Good, Knutson, Tilly, & Collins, 1992). R-CBM has been used to create school

and district norms (Deno, 1985; Shinn, 1988) and as a screening tool to identify lower performing at-risk students (Good, Gruba, & Kaminski, 2002). However, there has been a dearth of assessment tools of prereading, literacy skills, and limited methods to monitor students' progress or evaluate the effectiveness of interventions in these skills. Of specific need are measures that cross developmental periods related to early literacy skill, from birth, when language and communication skills begin to develop, through early elementary school.

Efforts have been made to extend the "rationale, procedures, and criteria" (Kaminski & Good, 1996, p. 216) of CBM to early literacy. The Dynamic Indicators of Basic Early Literacy Skills (DIBELS), developed by Kaminski and Good (1996), are widely used in kindergarten and first grade across the United States to screen and monitor students' progress in prereading (available at <http://www.dibels.uoregon.edu>). A similar extension of the CBM rationale, procedures, and criteria resulted in the development of measures, individually and collectively referred to as Individual Growth and Development Indicators (IGDIs), to be used with preschool children aged 3–5 years (McConnell, McEvoy, & Priest, 2002; Priest et al., 2001; available at <http://www.ggg.umn.edu>) and infants and toddlers (Greenwood, Luze, & Carta, 2002; Luze, Linebarger, Greenwood, Carta, & Walker, 2001; available at <http://www.igdi.ku.edu>).

Like R-CBM, the preschool Early Literacy IGDIs (EL-IGDIs) were designed to be easy to administer, inexpensive, reliable and valid, and sensitive to age and intervention effects (Priest et al., 2001). Preliminary research has focused primarily on the psychometric properties of the measures (McConnell, Priest, Davis, & McEvoy, 2002; Missall & McConnell, 2004; Missall, McConnell, & Cadigan, 2006), although some intervention studies have been completed (McConnell, Priest et al., 2002; Phaneuf & Silbergliitt, 2003). Over 35% of 2004 Early Reading First Grantees used EL-IGDIs to assess child language and literacy outcomes (U.S. Department of Educa-

tion, 2004) and the Pre-Elementary Education Longitudinal Study (2004; <http://www.peels.org/Assessments.asp>) adapted the measures for its national evaluation of young children. A literature review indicated that EL-IGDIs are the only currently available CBM-like measures of early literacy for ages 3–5.

Given the strong influence of early childhood and preschool experiences on early literacy development and the critical differences in literacy skill apparent among children at the start of school, it behooves educators to examine and link preschool measures of literacy skills with those used in primary schools. Once these links are established, this information may be used for screening and monitoring students' core literacy skills before school entry and for early identification of those at risk for later reading failure. Although EL-IGDIs have strong theoretical connections and adequate psychometric properties with preschool-aged children, there are currently no studies that link these measures to other measures of prereading administered in kindergarten and first grade or with reading proficiency over time. Therefore, the broad purpose of this study was to examine longitudinal growth on EL-IGDIs from preschool through the end of kindergarten and the relation of that growth to literacy and reading performance in kindergarten and first grade. More specifically, we examined three research questions: (a) Are EL-IGDIs sensitive to early literacy skill growth from preschool through the end of kindergarten? (b) What are the associations between performance on EL-IGDIs in preschool and performance on measures of early literacy skills and passage reading in kindergarten? and (c) What are the associations between performance on EL-IGDIs in preschool and reading at the end of first grade?

Method

Participants

Participants were children initially recruited for a university study conducted in preschools located within a 2-mile radius of low-performing, high-poverty elementary schools in

a large, urban school district in the Midwest. A sample of 398 children was recruited at age 4 to the university study. Of these children, 143 attended kindergarten in this school district and were selected for this project as a convenience sample. One-hundred sixteen students were still enrolled in the district at the end of first grade. Of the 143 students for whom preschool and kindergarten assessment data were collected, about 40% were African American, 34% were European American, 10% were Asian American, 10% were American Indian, and about 6% were Hispanic American. There were more females (54.5%) than males (45.5%) in the sample. Fifteen of the students were eligible for services because of limited English proficiency as English language learners, and out of those 15, 60% had a native language as Hmong, 20% had Spanish, 13% had Somali, and the remaining 7% were classified as Latvian or unknown. Fifty-eight percent of the students were eligible for free or reduced-price lunch. None of the students in the sample were eligible or served under special educational services.

Measures and Procedures

Procedures for data collection are described concurrently with each set of measures.

EL-IGDIs. Preschool EL-IGDIs, including Picture Naming, Rhyming, and Alliteration (Early Childhood Research Institute on Measuring Growth and Development, 1998, 2000), are typically administered at least three times per year, and often seasonally, in preschool to generate slope estimates of growth over time (McConnell, Priest et al., 2002; Missall et al., 2006). EL-IGDIs are described in the following paragraphs; however, a technical report that includes psychometric information and study descriptions for all EL-IGDIs can be found online at <http://www.ggg.umn.edu/techreports/dissemination.html#TechRep>. Graduate research assistants were trained on the administration of the EL-IGDIs and administered the measures on three occasions. Each administration lasted approximately 10 min per

child. Fidelity was evaluated with administration checklists available at http://www.ggg.umn.edu/get/procedures_and_materials/index.html. All research assistants met minimum reliability criteria of 90% on each measure before data collection.

Picture Naming. Picture Naming (PN) is completed by presenting children with pictures of objects found in natural environments, including the home (e.g., cake, sink), classroom (e.g., glue, book), and community (e.g., rabbit, train). Children are asked to name pictures as quickly as possible. The number of pictures named correctly in 1 min is the child's score.

Research on the psychometric properties of PN has suggested it is a valid indicator of children's expressive language skills. Adequate criterion validity has been reported previously (Priest, McConnell, McEvoy, & Shin, 2000) with the Peabody Picture Vocabulary Test (Dunn & Dunn, 1997; $r = .56-.75$) and the Preschool Language Scale (Zimmerman, Steiner, & Pond, 2002; $r = .63-.79$). Evidence of construct validity has also been reported with significant correlations found between PN and chronological age ($r = .41-.60$), including preschool children without identified risks ($r = .63$), children enrolled in Head Start ($r = .32$), and preschool children with disabilities ($r = .48$; McConnell, Priest et al., 2002). One-month alternate-form reliability coefficients have ranged from $r = .44$ to $.78$ (McConnell, Priest et al., 2002). Test-retest reliability across three weeks was $r = .67$. Hierarchical linear modeling (HLM) results centered at 66 months of age showed an average PN score (correct responses in 1 min) of 26.9 for children without identified risks, 19.0 for children living in low-income environments, and 16.9 for children with identified disabilities (Priest, McConnell et al., 2000). In a different longitudinal study, HLM results centered at 59 months of age showed an average PN score of 22.2 for children without identified risks, 18.9 for children with speech-language impairments, and 7.2 for

Spanish-speaking children learning English (Missall et al., 2006).

Rhyming. In Rhyming (RH), the child is presented with a card that has one stimulus picture on the top of the card (e.g., bees) and three pictures across the bottom of the card representing one correct and two incorrect responses (e.g., house, pants, cheese). The examiner points to and names each picture and instructs the child, "Point to the picture that sounds the same as the top picture." Each administration continues for 2 min and a child's score is the number of correctly identified rhymes. A child can receive a score of zero by failing the sample items at the beginning of the administration or by passing those items and then answering every administration item incorrectly (although the latter is a rarity).

Criterion validity of the RH IGDI was examined in previously reported research with moderate to high correlations with the Peabody Picture Vocabulary Test ($r = .56-.62$), Concepts About Print (Clay, 1985; $r = .54-.64$), and Test of Phonological Awareness (Torgeson & Bryant, 1994; $r = .44-.62$; McConnell, Priest et al., 2002). Studies of concurrent validity have found moderate to high correlations with PN ($r = .46-.63$) and Alliteration ($r = .43$; Missall, 2002), as well as with DIBELS (Kaminski & Good, 1996) measures of Letter-Naming Fluency ($r = .48-.59$) and Onset Recognition Fluency or Initial Sound Fluency ($r = .44-.68$; McConnell, Priest et al., 2002; Missall, 2002). Evidence of construct validity has been reported between RH and age, including children with disabilities and those living in poverty ($r = .46$; Priest, Silbergliitt, Hall, & Estrem, 2000). Test-retest reliability over three weeks was $r = .83-.89$ (Missall & McConnell, 2004). HLM results centered at 53 months of age showed an average RH score (correct responses in 2 min) of 7.6 for children without identified risks, 6.5 for children living in low-income environments, and 5.1 for children with identified disabilities (Priest, Silbergliitt et al., 2000). Results also showed that RH was

sensitive to children's monthly rate of growth, with children without identified risks gaining 0.4 rhymes per month, children from low-income families gaining 1.0 rhyme per month, and children with identified disabilities gaining 0.4 rhymes per month. In a different longitudinal study, HLM results centered at 59 months of age showed an average RH score of 12.0 for children without identified risks, 6.8 for children living in poverty, 5.8 for children with speech-language disabilities, and 0.3 for Spanish-speaking children learning English (Missall et al., 2006).

Alliteration. Similar to RH, Alliteration (AL) IGDI cards depict four pictures: at the top is a picture representing the stimulus word (e.g., cake) and under the stimulus picture is a row of three other pictures (e.g., cat, sink, bear) with one correct and two incorrect responses. The child is instructed, "Point to the picture that starts with the same sound as the top picture." AL is administered for 2 min and the score is the number of beginning sounds identified correctly. As with RH, a score of zero can be obtained by either failing all the sample items or by passing the sample items and then failing to answer any of the following items correctly.

Criterion validity of AL has been examined with the Peabody Picture Vocabulary Test ($r = .40-.57$), Test of Phonological Awareness ($r = .75-.79$), and Concepts About Print ($r = .34-.55$; McConnell, Priest et al., 2002). Concurrent validity with DIBELS Letter-Naming Fluency has been reported as moderate to high ($r = .49-.71$; McConnell, Priest et al., 2002; Missall, 2002). AL has been correlated with age ($r = .61$) and found to be stable over time with test-retest reliability over three weeks resulting in moderate to high correlations ($r = .62-.88$; Priest, Silbergliitt et al., 2000). There is also evidence that AL scores in preschool children vary by risk, income, and disability status (e.g., higher for students without risk or identified disabilities). HLM results centered at 53 months of age showed an average AL score (correct responses in 2 min) of 5.2 for children without

identified risks, 4.3 for children in low-income environments, and 4.4 for children with identified disabilities (Priest, Silberglitt et al., 2000). HLM results centered at 59 months of age showed an average AL score of 9.0 for children without identified risks, 4.4 for children living in poverty, 4.6 for children with speech–language impairments, and 3.8 for Spanish-speaking children learning English (Missall et al., 2006).

Kindergarten assessments. The Minneapolis Public Schools Kindergarten Assessments were administered to all students in the district in the fall and spring. In addition, a brief progress check was administered immediately following winter break. These assessments consisted of measures of early literacy and mathematical concepts; however, only fluency based measures of early literacy and reading are described here. Some research has been conducted on the technical adequacy and validity of these kindergarten assessments (Betts, Pickart, Heistad, & Sheran, 2005; Marston et al., 2007; Pickart, Sheran, Betts, Heistad, & Muyskens, 2006). In general, there is evidence of adequate test–retest and internal consistency reliability when examined as individual measures (Marston et al., 2007), domains (i.e., phonemic awareness, alphabetic principle), and as an overall early literacy composite (Pickart, Sheran, Betts, Heistad, & Muyskens, 2006). Further, the kindergarten assessments are highly correlated with first-grade R-CBM ($r = .80$) and moderately to highly correlated with spring of second-grade standardized test scores in reading ($r = .66$) and mathematics ($r = .60$; Pickart et al., 2006).

Temporary staff were hired and trained to administer and score the assessments. Assessors were typically retired kindergarten teachers trained by a district specialist in research and assessment. Administration time for the beginning- and end-of-kindergarten assessments was approximately 20 min on each occasion (all components); the winter progress check lasted approximately 10 min. Descriptions of each measure follow.

EL-IGDIs. PN, RH, and AL IGDIs were included as part of the fall and spring district-wide kindergarten assessments.¹ (EL-IGDIs were collected a total of five times in the study: three during the preschool year and two during kindergarten). Administration and scoring followed the standardized procedures described previously as part of the preschool EL-IGDI assessments.

Letter Naming. Research has consistently found that letter naming is predictive of later reading (Bishop, 2003; Scanlon & Vellutino, 1996). The district probe was administered in the beginning- and end-of-kindergarten assessments. To administer Letter Naming, the examiner presented a card with 70 randomly ordered lowercase letters and asked students to name letters as quickly as possible. The total number of correct letters named in 1 min was recorded.

Letter–Sound Correspondence. This measure was developed by the district to assess students' knowledge of letter sounds. The Letter–Sound Correspondence probe card had 70 randomly ordered lowercase letters. The assessor gave the following directions: "When I say begin, I want you to say the sound for the letter you see." Correct responses included common letter sounds. The total number of correct responses in 1 min was recorded. Letter–Sound Correspondence was administered to all students in the fall, winter, and spring of kindergarten.

Onset Phoneme Identification. The district's Onset Phoneme Identification measure was developed to assess phonemic awareness and was administered in the winter. The probe consisted of 18 words presented orally to the student. The examiner gave the following directions: "I will tell you a word and you will give me the first sound that you hear. If I say cat, you will say /k/." Items for the purpose of modeling and practice were presented before the measure was administered. The number of correct responses in 1 min was recorded.

Phoneme Segmentation. The district measure of Phonemic Segmentation was based on the work of Yopp (1988) and similar to the DIBELS segmentation measure (Marston et al., 2007). The same procedures were followed for the phoneme segmentation probe as the onset phoneme identification task. Words were presented aloud by the examiner to the student, but the students were instructed to say all the phonemes in the presented word. Directions were: "I will tell you a word and you will give me the sounds you hear in that word. If I say cat, you will say /k/ /a/ /t/." Sample items were administered for modeling and practice before probe items. The probe consisted of two- and three-phoneme words, and was scored by counting the correct number of phonemes isolated by the student in 1 min. The total number of correct responses was recorded. Phoneme Segmentation was administered in the spring of kindergarten.

Passage reading. In the end-of-kindergarten assessment, students were presented with one preprimer oral reading passage and asked if they could read any of the words on the page. If yes, then the passage was administered according to standard R-CBM procedures. The total number of words read correctly from the passage in 1 min was recorded. Some students were unable to read connected text at the end of kindergarten; however, this measure was included so that a full range of student skill could be captured by the assessment.² End-of-kindergarten passage reading has been used in the district since the 2001–2002 school year and has been found to be correlated with first-, second-, and third-grade reading (Pickart et al., 2006).

First-grade reading. R-CBM assessments were administered to all students in the spring of first grade as part of the district's assessment program. Three first-grade reading passages were administered according to standard R-CBM procedures (e.g., standardized instructions and guidelines, time limits). The number of words read correctly in 1 min for each passage was recorded (total number of

words read *minus* incorrect words). Words read correctly was defined as words pronounced correctly within the context of the sentence. Mispronunciations, reversals, and omissions were marked as incorrect. The average number of words read correctly for the three passages was used for data analysis in this study. The mean has typically been used in the district because its research has found higher reliability and validity coefficients with the mean R-CBM score, as opposed to the median score, in the spring of first grade.

Data Analysis

To address the research questions, a number of quantitative methods were used. Descriptive statistics provided an initial description of the mean and variation in variables, and correlations provided basic evidence for predictive validity. Distributions of the variables were investigated, which lead to the use of zero-inflated Poisson models for parts of the analysis. Zero-inflated Poisson models are useful when handling count data with positive skewing, overdispersion, and an excessive number of zero scores (Hall, 2000; Lambert, 1992; McLachlan & Peel, 2000). Zero-inflated Poisson models allow for analysis of two processes: one with respect to the zero outcomes and one with respect to the nonzero outcomes (Lambert, 1992; Muthen & Muthen, 2005).

Analyses investigated trends over time on each of the EL-IGDIs using a latent variable growth approach (Bollen, 1989; Duncan, Duncan, Strycker, Li, & Alpert, 1999). In addition, a general latent variable model (Bollen, 1989) was used to evaluate the relation between preschool measures and kindergarten measures. EL-IGDIs were modeled as observed indicators of a general early literacy latent variable measured at three distinct times during the pre-kindergarten year. Early reading skills assessed during kindergarten were similarly modeled. This allowed for modeling the direct and indirect effects of early literacy variables measured in preschool on the skills measured during kindergarten.

Multiple regression models were used to analyze the relation between preschool EL-IGDIs and the end-of-kindergarten and end-of-first-grade reading skills as measured by R-CBM. The relation of the preschool measures to the end-of-first-grade reading was also analyzed using a logistic regression model (Hosmer & Lemeshow, 2000) to investigate the EL-IGDIs with respect to whether students reached the benchmark criteria of reading correctly at least 60 words per minute on the first-grade R-CBM assessment. To facilitate this analysis, scores on the first-grade R-CBM were classified into two groups based on whether they achieved at least 60 words read correctly within 1 min—henceforth referred to as “masters” or “nonmasters.” As a by-product of the results of the logistic regression, it was possible to compute classification and diagnostic accuracy indices. We computed the following indices: total classification accuracy, sensitivity, specificity, positive predictive power, negative predictive power, false positives, and false negatives. Sensitivity was computed with respect to the students who did not meet the benchmark at the end of first grade.

Results

Descriptive Analyses

Descriptive data for all measures are in Table 1. Results indicated growth in mean scores from preschool to the end of kindergarten on PN, RH, and AL IGDIs. The score increase was quite small during preschool and substantial during kindergarten, and scores on several of the measures indicated a floor effect. These measures also tended to show large variations, as demonstrated by comparing standard deviation and mean values. An investigation of the distributions showed several measures had non-normal distributions as determined by skewness and kurtosis values greater than two times the standard error of the statistic, including: preschool fall, winter, and spring RH; preschool fall, winter, and spring AL; kindergarten fall AL, Letter Naming, and Letter–Sound Correspondence; and kindergar-

ten spring R-CBM. All of the remaining measures had higher order moments, indicating normal distributions, and were treated as such.

Along with the identification of the floor effect and large skew in distribution, many zero responses were found in the preschool data. For the fall, winter, and spring preschool observations of RH, 39%, 43%, and 37% of the distribution was found to be zeros, respectively, and 47%, 60%, and 52% for AL, respectively. For the kindergarten fall AL and Letter–Sound Correspondence, the frequency of zeros was 14% and 37%, respectively. The last two non-normal variables, kindergarten fall Letter Naming and kindergarten spring R-CBM, had 9% and 3.5% zeros, respectively. Letter Naming was transformed to normality by square root and the spring R-CBM variable transformed to normality by natural logarithm of the number correct plus one. All references and results of the spring R-CBM scores were computed on the transformed scores but reported as words read correctly per minute by applying the inverse transformation.

Pearson product moment correlations are reported in Table 2. It should be noted that these correlations were attenuated due to restriction of range as indicated above. Each of the preschool administrations of the EL-IGDIs was moderately correlated with measures of alphabetic principle (Letter Sounds and Letter Names) administered in the fall of kindergarten. Low to moderate correlations were found with measures of alphabetic principle and phonological awareness administered in the winter and spring of kindergarten. However, some correlations were not found to be significantly different from zero in this small sample.

Growth Analysis of IGDIs From Preschool Through Kindergarten

Missing data were found at some measurement occasions. All students were expected to be measured at all times; however, some students were not in attendance or available for follow-up and were not measured. Little’s test (Little, 1988) was used to evaluate the extent to which the data could be consid-

Table 1
Descriptive Data

Variable	Mean	<i>SD</i>	Range
Preschool 1: Fall (<i>N</i> = 110)			
Picture Naming	18.0	7.45	4–39
Rhyming	3.9	5.34	0–20
Alliteration	2.2	3.32	0–15
Preschool 2: Winter (<i>N</i> = 130)			
Picture Naming	20.5	7.46	3–42
Rhyming	5.4	6.31	0–21
Alliteration	2.5	4.12	0–18
Preschool 3: Spring (<i>N</i> = 125)			
Picture Naming	21.7	7.44	0–40
Rhyming	6.5	6.79	0–23
Alliteration	3.0	4.52	0–21
Beginning of kindergarten (<i>N</i> = 143)			
Picture Naming	28.5	7.04	3–48
Rhyming	10.2	6.71	0–27
Alliteration	6.2	5.93	0–39
Letter Sounds	5.5	7.34	0–34
Letter Naming	17.3	13.87	0–62
Winter progress check (<i>N</i> = 132)			
Letter Sounds	21.6	15.55	0–71
Onset Phonemes	19.5	9.89	0–43
End of kindergarten (<i>N</i> = 136)			
Picture Naming	31.9	6.70	11–46
Rhyming	13.6	7.14	0–28
Alliteration	11.9	6.50	0–26
Letter Sounds	34.3	19.45	0–87
Letter Naming	34.2	17.80	0–91
Phonemic Segmentation	31.7	18.92	0–81
Passage Reading	25.6	28.38	0–125
First-grade oral reading (<i>N</i> = 116)			
Below 60 wpm benchmark (<i>N</i> = 58)	29.3	18.56	0.67–200.33
Above 60 wpm benchmark (<i>N</i> = 58)	104.0	33.63	

Note. wpm = Words per minute.

ered missing completely at random (Little & Rubin, 1987). Results indicated the hypothesis of missing completely at random could not be rejected ($\chi^2[92] = 97.84, p = .31$). Therefore, students with complete data were treated as a random subsample and estimates unbiased with respect to the original sample (Little & Rubin, 1987; Lohr, 1999).

For the latent growth analysis, each individual EL-IGDI (PN, RH, and AL) was

evaluated longitudinally as a set of latent trajectory variables (Bollen & Curran, 2006; Duncan et al., 1999). Latent growth trajectories were modeled with latent intercept, linear, and quadratic components. The quadratic component was used to evaluate the apparent nonlinear mean growth (see Table 1). For the PN variable a normal model was used as PN at all times appeared to be normally distributed and the maximum likelihood estimator was

Table 2
Correlations Between Preschool Early Literacy Measures and Criterion Measures

Predictive Measures	Criterion Measures								
	Fall of Kindergarten		Winter of Kindergarten			Spring of Kindergarten			First-Grade Oral Reading
	Letter Sounds	Letter Names	Letter Sounds	Onset Phonemes	Letter Sounds	Letter Names	Phonemic Segmentation	Passage Reading	
Preschool fall									
Picture Naming	.54**	.59**	.34**	.29**	.32**	.43**	.31**	.37**	.42**
Rhyming	.47**	.49**	.31**	.35**	.26**	.35**	.33**	.26**	.37**
Alliteration	.47**	.49**	.08	.09	.17	.34**	.15	.29**	.26**
Preschool winter									
Picture Naming	.51**	.54**	.28**	.40**	.30**	.45**	.32**	.42**	.48**
Rhyming	.53**	.55**	.19*	.22*	.16	.38**	.33**	.36**	.41**
Alliteration	.55**	.51**	.27**	.18	.23**	.33**	.22*	.48**	.43**
Preschool spring									
Picture Naming	.49**	.49**	.28**	.37**	.27**	.29**	.36**	.36**	.37**
Rhyming	.50**	.59**	.28**	.31**	.30**	.41**	.41**	.42**	.51**
Alliteration	.59**	.61**	.24**	.23**	.29**	.43**	.24*	.58**	.50**

* $p < .05$.
** $p < .01$.

used. However, RH and AL were modeled as a zero-inflated Poisson, using robust maximum likelihood estimators; diagnostic indices indicated the models converged to global optima as evaluated by the equality of likelihood estimates from 10 different starting values.

Picture Naming. Results indicated the quadratic parameter was not significantly different from zero. The resulting linear model appeared to fit the data moderately well as measured by the standardized root mean square residual (SRMR = .10), comparative fit index (CFI = .89), and Tucker-Lewis Index (TLI = .89). The linear model resulted in parameter estimates indicating that children on average started preschool naming about 18 pictures. Children had an average slope parameter of about three pictures per measurement period, indicating they on average increased their PN score by about 6 over the

course of the preschool year. An interesting result was the significant negative correlation ($r = -.51$) between the latent intercept factor and the latent slope parameter, indicating that children who initially scored lower on PN tended to have more rapid rates of increase on PN over the 2 years of preschool and kindergarten than children scoring higher.

Rhyming. As with the PN model, the quadratic parameter was not significantly different from zero in the Poisson process of the model for students not in the zero group class. Therefore, the quadratic parameter was dropped from the model. Results of this model indicated that the probability of being in the zero class at the beginning of the preschool year was about 49% and it decreased at each measurement point to only a 10% probability by the fall of kindergarten and less than a 0.1% probability by the end

of kindergarten. This indicates that children entering preschool were just as likely to be able to answer at least one item correctly as not answer any items correctly. However, the probability decreased over time and by the beginning of kindergarten it was highly likely that a student answered at least one item correctly and almost all students were able to answer one item correctly by the end of kindergarten. Results for the students who were not in the zero class indicated that a linear growth model was the most appropriate. The model indicated that these students, on average, increased about two items correct at each time point. By the end of the preschool year the children were expected to earn scores around 9, and by the end of kindergarten, students were able to identify about 13 rhymes.

Alliteration. A similar model was used for the AL variables as with the RH model. This time all the latent trajectory variables for the intercept, linear slope, and quadratic term were significant. There was about a 59% chance that a child starting preschool would not be able to answer at least one AL item correctly. This probability decreased over preschool to about a 53% chance of scoring zero by the end of the school year. Children in the sample had about a 20% chance of being in the zero class at the beginning of kindergarten, but by the end of kindergarten less than 0.1% of the students were expected to be in the zero class. Students in the nonzero class showed a significant positive increase from a score of about 2 correct at the beginning of preschool to about 12 correct by the end of kindergarten. The linear slope parameter was about $-.08$ and the quadratic curvature parameter was about $.42$, indicating a concave up-growth curve with constant acceleration. The rate of change was a positive function of the time of measurement, suggesting the rate of change early in the preschool year was not as rapid as during kindergarten.

Relation Between EL-IGDIs and Kindergarten Measures

Table 2 provides estimates of the validity coefficients between each of the EL-IGDIs

and the kindergarten measures. Most correlations were significant. To analyze the effect of the preschool measures on the beginning-of-kindergarten performance, each preschool measurement occasion was treated independently and the beginning-of-kindergarten assessment scores on RH, AL, Letter Sounds, and Letter Names were used as observed indicators of a general early literacy factor (see Figure 1). Because of the non-normality and excess kurtosis in the preschool variables, RH, and AL, the weighted least squares estimator was used to handle the potential bias in estimation of standard errors (Bollen, 1989). Results of the three latent variable models are in Table 3. The table shows results of each of the preschool early literacy variables in relation to the underlying latent factor (L1–L3), the early reading skills observed variables to the underlying latent early reading skills variable (L4–L7), and the direct effect of the preschool latent early literacy variable on the kindergarten latent early reading skills variable (G1).

Examination of the fit statistics determined a moderate fit of all the models to the data. Because of the exploratory nature of this study and the small sample size, no adjustments to the models were undertaken to help improve fit. One option would have been to indicate correlated residuals at, or between, each measurement occasion or to model latent growth factors of EL-IGDIs across time. The percentage of variance accounted for in each of the kindergarten latent variables reflecting early reading skills attributable to the early literacy measures increased over time and was quite substantial. Large direct effects also indicated a standard deviation change in the early literacy latent variable results with almost a complete standard deviation change in the early reading latent variable.

Direct effect of the early literacy latent variable, as measured by the preschool EL-IGDIs, on the beginning-of-kindergarten reading skills was represented by the G1 parameter estimate. All indirect effects of the early literacy latent variable on observed variables at kindergarten are the product of the G1 variable and the specific coefficient estimate (L_x). For

instance, the indirect effect of changes in the fall early literacy latent variable on the LN variable at the beginning of kindergarten is about 0.76 ($G1 \times L6 = 0.91 \times 0.84 = 0.76$). This indicates that a standard deviation unit change in early literacy skills at the fall of preschool was expected to result in about a three-quarters standard deviation shift in the LN variable at the beginning of kindergarten. The results indicated large and substantial direct and indirect effects.

To evaluate the effects of preschool fall EL-IGDIs on end-of-kindergarten R-CBM, the EL-IGDIs measured at each time point during the preschool year were summed to a total score. Summing the measures at each time point resulted in distributions that were normally distributed. Results indicated the fall preschool measure ($n = 104$) was correlated .38 ($p < .01$) with the end-of-kindergarten measure of R-CBM; the winter preschool measure ($n = 124$) was correlated .50 ($p < .01$), and the spring measurement ($n = 118$) was correlated .51 ($p < .01$). All measures were found to be significantly linearly related to end-of-kindergarten R-CBM.

Two follow-up analyses were completed with respect to the AL and RH IGDIs independently. Because a large number of children scored zero on these measures during preschool, it was important to evaluate how the zero class (children with a score of zero at each time) performed in comparison to the nonzero class (children with at least one score above zero) on the end-of-kindergarten R-CBM. To evaluate differences in oral reading fluency rates, a regression analysis was run using R-CBM as the outcome variable and group membership as the predictor. However, just the RH measure was investigated because only 2 students had complete data on AL during preschool as well as the end-of-kindergarten R-CBM.

Fifty-three students had completed preschool RH and end-of-kindergarten measures; 30 students were in the zero class and 23 were in the nonzero class. The regression model was significant ($F[1,51] = 11.45, p < .001, R^2 = .18$). Parameter estimates indicated that the nonzero class averaged about 41 words read correctly per minute at the end of kindergarten whereas the zero class only averaged about 14.

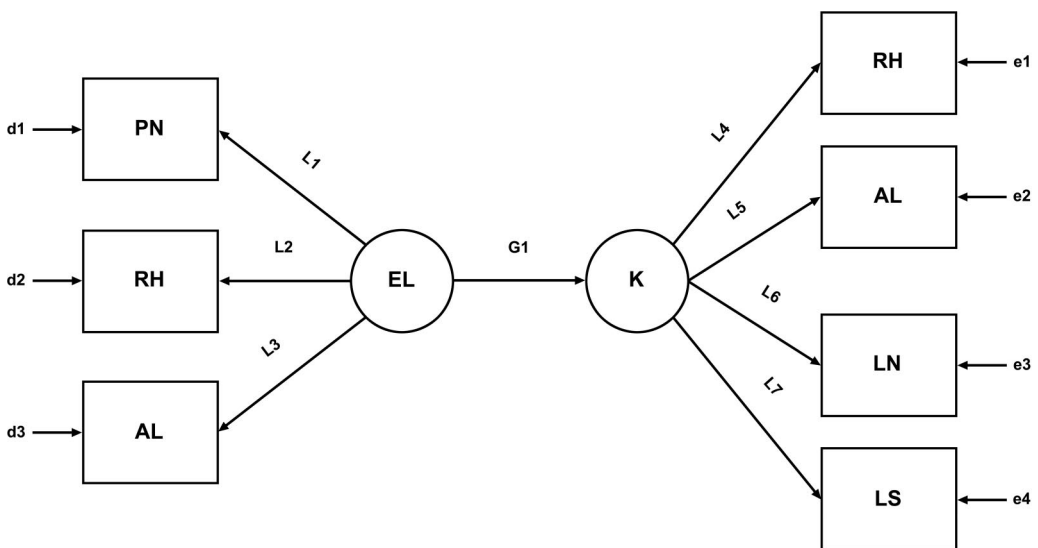

Figure 1. Latent variable measurement and structural equation model for Early Literacy Individual Growth and Development Indicators' effects on kindergarten reading skills

Table 3
Latent Variable Model Standardized Estimates at Each Preschool
Measurement Time with Beginning of Kindergarten Reading Skills

Parameter	Fall Preschool	Winter Preschool	Spring Preschool
L1	0.71	0.66	0.68
L2	0.73	0.70	0.79
L3	0.64	0.68	0.74
L4	0.74	0.73	0.82
L5	0.83	0.86	0.86
L6	0.84	0.83	0.78
L7	0.84	0.81	0.81
G1	0.91	1.00	0.98
R^2	.83	.88	.97
χ^2	39.93	54.95	70.62
df	13	13	13
p Value	<.001	<.001	<.001
CFI	.94	.92	.90
TLI	.90	.87	.84
RMSEA	.14	.16	.19
SRMR	.05	.05	.06

Note. [L1 = preschool PN; L2 = preschool RH; L3 = preschool AL; L4 = kindergarten RH; L5 = kindergarten AL; L6 = kindergarten LN; L7 = kindergarten LS; G1 = preschool early literacy with beginning of kindergarten reading]. R^2 indicates the percent of variance of the beginning of kindergarten latent variable explained by the early literacy latent variable; CFI = comparative fit index; TLI = Tucker–Lewis index; RMSEA = root mean square error of approximation; SRMR = standardized root mean square residual.

The zero class was found to be significantly behind the nonzero class of students.

Relation Between EL-IGDIs and First-Grade Oral Reading

Table 2 provides validity coefficients of each EL-IGDI with the end-of-first-grade R-CBM. For further analysis of the relation between the preschool measures and the end-of-first-grade R-CBM, we used the total score at each time (as done in the previous analysis with respect to end-of-kindergarten R-CBM scores). Results indicated the fall ($n = 88$, $r = .46$, $p < .01$), winter ($n = 106$, $r = .54$, $p < .01$), and spring ($n = 101$, $r = .54$, $p < .01$) measures were significantly correlated with the end-of-first-grade R-CBM.

Differences in the end-of-first-grade R-CBM between the zero class ($n = 25$) and the nonzero class ($n = 20$) with respect to RH

were evaluated. The regression analysis was significant ($F[1, 43] = 22.66$, $p < .001$, $R^2 = .35$). Parameter estimates for the model indicated that the nonzero class averaged about 95 words read correctly per minute as opposed to the 36 words averaged by the zero class at the end of first grade. It was also possible to classify the students with respect to their zero-class status and to their status on the end-of-first-grade R-CBM benchmark (whether they achieved 60 words read correctly per minute). This classification allowed for the computation of the odds ratio, which indicated that students in the nonzero class during preschool were almost 12.7 times more likely to meet the benchmark than were students in the zero class.

A final logistic regression was used to determine how well the EL-IGDIs, administered in the fall of preschool, correctly classified those who reached an end-of-first-grade

R-CBM benchmark of 60 words per minute, indicating a grade-appropriate reading level (Fuchs, Fuchs, & Deno, 1982; Minneapolis Public Schools Content Standards, n.d.). Of the 88 students who had R-CBM data and complete fall of preschool data, 53% of the sample ($n = 47$) achieved this benchmark. The results of the logistic regression were significant ($\chi^2[3] = 20.97, p < .001$, Nagelkerke $R^2 = .28$). Parameter estimates indicated the RH and AL variables did not significantly increase prediction. However, using only the PN variable in the model, the correct classification increased from about 53% to about 73%, which is almost a 38% increase in correct classification. Diagnostic accuracy indices indicated sensitivity to be about 64% and specificity to be about 81%. Results further indicated that the percentage of false negatives was about 36% and false positives about 19%. The positive predictive power was found to be about 74% and the negative predictive power was about 72%.

Discussion

Learning to read is one of the most important milestones of childhood. Indeed, reading is critical for success throughout school and in life. As such, it is not surprising that reading, or more accurately improving the reading proficiency of students across the United States, is the subject of considerable debate and concern. It is increasingly recognized that preschool and kindergarten are opportune times to promote literacy development and to screen and intervene at the first signs of reading difficulties. Therefore, the purpose of this study was to examine measures of early literacy from preschool through the end of kindergarten and the link between preschool measures and later reading.

In general, results indicated the EL-IGDIs were sensitive to growth in preschool, as demonstrated in previous studies (Priest, McConnell et al., 2000), and the measures continued to be sensitive to growth across kindergarten. This was true in terms of scores of individual measures and the total score of all

measures summed together. In terms of validity, previous research examined the concurrent validity of the EL-IGDIs with other early literacy measures, namely the DIBELS (Kaminski & Good, 1996), revealing low to moderate correlations (McConnell, Priest et al., 2002; Missall, 2002). However, this study was among the first to examine the longitudinal associations between preschool administrations of the EL-IGDIs and kindergarten measures of early literacy skills and reading fluency at the end of kindergarten and first grade. Although the size of the correlations varied, most were significant and in the low to moderate range.

An interesting finding arose out of the large, negative correlation of initial status and growth over time on the PN task, whereby students with higher scores tended to grow more slowly than students with lower initial scores. When examining the effects of the EL-IGDIs as a single factor on later reading skills, changes in the EL-IGDIs predicted large changes in later early reading skills. This suggests that any attempt to increase a student's early literacy skills with respect to language, rhyming, and alliteration should result in positive shifts in that student's later reading skills. This type of finding helps to bolster support for intervention research and the potential long-term effects on later reading ability of students.

Also of interest is the diagnostic utility of the PN IGDI in identifying later outcomes. Measures of sensitivity and specificity were fair, but of more importance were the higher levels of positive predictive power and negative predictive power. The positive predictive power and negative predictive power are more likely to reflect intended use of the measure as educators will want to use the measure to predict later status. Arguably, one of the more compelling findings of this study was the level with which the PN IGDI at the fall of preschool correctly classified first-grade readers (72.7%). These results should be interpreted within the context of the exploratory nature of this study and small sample sizes. However, they provide a strong basis for follow-up large-scale studies.

Results of RH IGDI provided some insight into students' early literacy skill development by indicating that preschoolers unable to answer a single item correctly had a much lower reading outcome both at the end of kindergarten and the end of first grade when compared to preschoolers able to answer at least one item correctly on at least one occasion in preschool. Because of the small sample sizes, it was impossible to complete a similar analysis with the AL IGDI. However, given these results, it appears to be a provocative follow-up analysis.

Several implications and caveats may be drawn from this study and more broadly from work in early literacy assessment and early intervention. First, our results indicate that it is possible to assess children's literacy skills and growth in these skills before the start of formal schooling. Furthermore, this information can be collected and maintained across a continuum from preschool through kindergarten. Given what is known about the development of foundational literacy skills (e.g., language, phonological awareness, concepts of print) from birth to age 5, the striking differences that exist among students at the commencement of formal schooling, and the long-term nature of reading difficulties not effectively remediated by Grades 2 or 3 (Juel, 1988; Stanovich, 1986), there is a clear rationale for literacy assessment before school entry and in the first year of formal schooling. Moreover, the assessment tools are available. The issue, then, becomes one of purpose and utility.

Any number of assessment tools or variables might be used to predict which students will fail in school or which students may have difficulty learning to read (e.g., students with disabilities, living in poverty, those who speak English as a second language). However, measures such as those described in this study may be used for the early identification of students who are at risk for later reading problems before problems are severe and gaps between good readers and poor readers are large. Furthermore, measures like these also support the critical link between assessment and intervention practices (Reschly, 1988). There is prom-

ise that these measures, developed in the mold of CBM, may be used in a CBM-like manner within a problem-solving model (Deno, 1989) to monitor effects of interventions and to guide changes based on students' own data to affect the greatest rate of skill growth.

An example of the utility of early literacy assessment may be found in the work conducted by the Minneapolis Public Schools. Benchmarks for student performance have been set using the kindergarten assessments (Pickart et al., 2006). Kindergarten benchmarks have been linked to first-grade oral reading and passing scores on the state-mandated high-stakes reading assessment administered in the third grade. These benchmarks have allowed the district to identify students "not on track" for reaching desired levels of proficiency on state-mandated assessments *years before the administration of such assessments*, providing valuable opportunities for early intervention. This information has also been used for program evaluation and to identify outstanding teachers and/or instructional methods. In addition, Minneapolis Public Schools currently uses a problem-solving model for screening, early intervention, and if necessary, special education eligibility determination, to address both academic and behavioral concerns (Marston, Muyskens, Lau, & Canter, 2002; Muyskens, Marston, & Reschly, 2005). The Kindergarten Assessments are an important part of this problem-solving model, linking kindergarten to the process and measures already in place for other elementary grades.

Although there is great promise in this type of work for screening and early intervention with reading difficulties, it is a complicated science. Research is clear that multiple early literacy skills contribute to reading acquisition (see Snow et al., 1998; Whitehurst & Lonigan, 1998). The predictive validity of the various skills, however, can make data interpretation and instructional and intervention planning somewhat difficult. In the words of Kaminski and Good (1998), "Early literacy skills such as phonological awareness, print awareness, and letter naming generally are not important tool skills in their own right. Instead, they are transitory, [or] *enabling*, skills

that facilitate the acquisition of reading, [which is] an important tool skill” (p. 123).

Limitations and Future Research

In any longitudinal study, the attrition of subjects is a limitation, possibly confounding results—certainly this study is no exception. Results in this analysis were based upon the assumption that data were missing completely at random, which was inferred from the results of a single statistical estimator and the research design, which attempted to include all students at each measurement; therefore, estimates should not be biased. Researchers should be aware of this problem and design future studies to ameliorate, to the extent possible, the effects. Along with good follow-up procedures for assessing students who may have been absent on a testing occasion, a viable option would be to gather salient demographic variables. With the collection of important background variables, researchers may be able meet the less restrictive case of missing at random.

Another important issue that arises is the generalizability of the estimates and predictive relationships to a larger population of students. The sample in this study was small and highly selective. The students represented a select group of children from families living in poverty in a particular geographical region. There is compelling evidence that children who live in poverty are disproportionately represented in the number of children who experience school difficulty, special education placement, and school dropout (Puma et al., 1997; Snow et al., 1998). Although these statistics make it all the more important to intervene with this population, it must be considered when interpreting findings from this study.

This study is at the beginning of a line of necessary research on preschool literacy assessment and intervention. One important avenue of future work is to create benchmark scores for EL-IGDIs to apply meaning. Currently, when a 4-year-old child completes PN, we are uncertain which score, or range of scores, reflects “on-track” or “at-risk” performance.

Determining these benchmarks is a critical step in influencing the utility of the measures.

Results from this study provide preliminary evidence of predictive validity with respect to reading, but the exploratory nature and limited sample does not warrant identification of benchmark scores from these data. Once these scores are set, however, a second necessary step involves following up with students who are at risk and in need of more frequent monitoring than a standard seasonal schedule. At this time, each of the EL-IGDIs is sensitive to a monthly rate of growth (cf. McConnell, Priest et al., 2002; Missall & McConnell, 2004; Priest, McConnell et al., 2000), although rates vary per measure and per sample and tend to be too small for effectively determining response to intervention. Further, although EL-IGDIs were designed for use with preschool children from 3 to 5 years of age, there is speculation about whether all three measures are appropriate for the full age range for all children. For example, this and other research has shown floor effects on the measures, particularly RH and AL, which may indicate that tasks are quite difficult for a good deal of preschoolers, and ceiling effects for PN for children without risk factors (Estrem, McConnell, & Mein, 2006; Missall, 2002; Missall et al., 2006). However, this is the first study to discern, at least on the RH IGDI, how the floor effect may actually provide information.

The specific age range for sensitivity of each of the EL-IGDIs needs to be determined. Similarly, it is currently unknown how cut scores may link the EL-IGDIs together. If, for example, PN measures skills that emerge before RH and AL, it would be helpful to know what PN scores indicated and whether that child was developmentally ready for assessment with RH and AL. As results of this research indicated, the probability of being able to respond correctly to RH and AL items increased remarkably across preschool and kindergarten. Further exploration of the zero-class classification approach may be helpful in such an endeavor as it may provide a method to evaluate the probability of leaving the zero class based on PN score.

Interestingly, the developmental period before formal schooling and the initiation of formal schooling in kindergarten are generally viewed as separate and distinct entities. Yet, it is clear that children do not enter kindergarten as blank slates; there are large differences in acquired educational skills, opportunities, and experiences before children ever cross the doors of our nation's schools. The preschool years are a time of tremendous growth and provide an incredible opportunity for education, assessment, and early intervention. However, amending the typical K–12 education perspective to include preschool requires a significant paradigm shift, one in which school psychologists, with their backgrounds in child development, assessment, and consultation, are in a unique position to lead.

Footnotes

¹Given the time and financial commitments of administering a comprehensive assessment to all kindergarten students in the district, full Minneapolis Kindergarten Assessments are administered in the fall and spring. This administration schedule allows for the identification of students below benchmark levels of performance for the purposes of early intervention, the calculation of growth across the school year, and evaluation and comparison of students' performance from year to year.

²No floor effects have been found for this measure; 4% of students in this study earned 0 on this task.

References

- Adams, M. (1990). *Beginning to read: Thinking and learning about print*. Cambridge, MA: MIT Press.
- Aram, D. M., Ekelman, B. L., & Nation, J. E. (1984). Preschoolers with language disorders: Ten years later. *Journal of Speech and Hearing Research, 27*, 232–244.
- Ardoin, S. P., Witt, J. C., Suldo, S. M., Connell, J. E., Koenig, J. L., Resetar, J. L., Slider, N. J., & Williams, K. L. (2004). Examining the incremental benefits of administering a MAZE and three versus one curriculum-based measurement reading probes when conducting universal screening. *School Psychology Review, 33*, 218–233.
- August, D., & Hakuta, K. (Eds.). (1997). *Improving schooling for language-minority children: A research agenda*. Washington, DC: National Academy Press.
- Baker, S. K., & Good, R. H. (1995). Curriculum-based measurement of English reading with bilingual Hispanic students: A validation. *School Psychology Review, 24*, 561–579.
- Bashir, A. S., & Scavuzzo, A. (1992). Children with language disorders: Natural history and academic success. *Journal of Learning Disabilities, 25*, 53–65.
- Betts, J., Pickart, M., Heistad, D., & Sheran, C. (2007). *Construct and predictive validity evidence for curriculum-based measures of early literacy and numeracy skills in kindergarten*. Manuscript submitted for review.
- Bishop, A. G. (2003). Prediction of first-grade reading achievement: A comparison of fall and winter kindergarten screenings. *Learning Disability Quarterly, 26*(3), 189–202.
- Bollen, K. (1989). *Structural equations with latent variables*. New York: John Wiley & Sons.
- Bollen, K., & Curran, P. (2006). *Latent curve models: A structural equation perspective*. Hoboken, NJ: John Wiley & Sons.
- Clay, M. E. (1985). *Concepts about print*. Westport, CT: Greenwood Publishing.
- Deno, S. L. (1985). Curriculum-based measurement: The emerging alternative. *Exceptional Children, 52*(3), 219–232.
- Deno, S. L. (1989). Curriculum-based measurement and special education services: A fundamental and direct relationship. In M. R. Shinn (Ed.), *Curriculum-based measurement: Assessing special children* (pp. 1–17). New York: Guilford Press.
- Deno, S. L. (1997). Whether thou goest. . . Perspectives on progress monitoring. In J. W. Lloyd, E. J. Kameenui, & D. Chard (Eds.), *Issues in educating students with disabilities* (pp. 77–99). Mahwah, NJ: Erlbaum.
- Duncan, T., Duncan, S., Strycker, L., Li, F., & Alpert, A. (1999). *An introduction to latent variable growth curve modeling: Concepts, issues, and applications*. Mahwah, NJ: Lawrence Erlbaum Associates.
- Dunn, L. M., & Dunn, L. M. (1997). *Peabody picture vocabulary test* (3rd ed.). Shoreview, MN: American Guidance Service.
- Early Childhood Research Institute on Measuring Growth and Development. (1998, 2000). *Individual Growth and Development Indicators for preschool children: Picture Naming/expressing meaning, Rhyming/early literacy, Alliteration/early literacy, Picture Naming in Spanish/expressive meaning*. Available online from Center for Early Education and Development, University of Minnesota, Minneapolis, Web site: <http://www.getgotgo.net>
- Espin, C. A., & Deno, S. L. (1995). Curriculum-based measures for secondary students: Utility and task specificity of text-based reading and vocabulary measures for predicting performance on content-area tasks. *Diagnostique, 20*, 121–142.
- Estrem, T., & McConnell, S. (2007). *Early literacy development of immigrant preschoolers who are Somali-, Spanish-, and Hmong-speaking*. Manuscript submitted for publication.
- Fey, M. E., Catts, H., & Larrivee, L. S. (1995). Preparing preschoolers for the academic and social challenges of school. In S. F. Warren (Ed.), *Language intervention in preschool through the elementary years* (pp. 225–290). Baltimore, MD: Brookes.
- Fletcher, J. M., & Lyon, G. R. (1998). Reading: A research-based approach. In W. M. Evers (Ed.), *What's gone wrong in America's classrooms*. Palo Alto, CA:

- Board of Trustees of the Leland Stanford Junior University, Hoover Institution Press.
- Fuchs, L. S., & Deno, S. L. (1991). Paradigmatic distinctions between instructionally relevant measurement models. *Exceptional Children, 57*, 488–500.
- Fuchs, L. S., Fuchs, D., & Deno, S. L. (1982). Reliability and validity of curriculum-based informal reading inventories. *Reading Research Quarterly, 18*, 6–26.
- Fuchs, L. S., Fuchs, D., & Maxwell, L. (1988). The validity of informal reading comprehension measures. *Remedial and Special Education, 9*, 20–28.
- Goals 2000, Education America Act. (1994). Retrieved March 24, 2006, from <http://www.ed.gov/legislation/GOALS2000/TheAct/index.html>
- Good, R. H., Gruba, J., & Kaminski, R. A. (2002). Best practices in using Dynamic Indicators of Basic Early Literacy Skills (DIBELS) in an outcomes-driven model. In A. Thomas & J. Grimes (Eds.), *Best practices in school psychology IV* (4th ed., Vol. 1, pp. 699–720). Washington, DC: National Association of School Psychologists.
- Greenwood, C. R., Luze, G. J., & Carta, J. J. (2002). Assessment of intervention results with infants and toddlers. In A. Thomas & J. Grimes (Eds.), *Best practices in school psychology IV* (4th ed., Vol. 2, pp. 1219–1230). Washington, DC: National Association of School Psychologists.
- Gutierrez-Clellan, V. F. (1999). Mediating literacy skills in Spanish-speaking children with special needs. *Language, Speech, and Hearing Services in Schools, 30*, 285–292.
- Hall, D. (2000). Zero-inflated Poisson and binomial regression with random effects: A case study. *Biometrics, 56*, 1030–1039.
- Hart, B., & Risley, T. (1995). *Meaningful differences in the everyday experiences of young American children*. Baltimore, MD: Brookes.
- Hintze, J. M., Shapiro, E. S., Conte, K. L., & Basile, I. M. (1997). Oral reading fluency and authentic reading material: Criterion validity of the technical features of CBM survey-level assessment. *School Psychology Review, 26*, 535–553.
- Hintze, J. M., & Silbergliitt, B. (2005). A longitudinal examination of the diagnostic accuracy and predictive validity of R-CBM and high-stakes testing. *School Psychology Review, 34*, 372–286.
- Hosmer, D., & Lemeshow, S. (2000). *Applied logistic regression* (2nd ed.). New York: John Wiley & Sons.
- Juel, C. (1988). Learning to read and write: A longitudinal study of 54 children from first through fourth grades. *Journal of Educational Psychology, 80*, 437–447.
- Kaminski, R. A., & Good, R. H. (1996). Toward a technology for assessing basic early literacy skills. *School Psychology Review, 25*, 215–227.
- Kaminski, R. A., & Good, R. H. (1998). Assessing early literacy skills in a problem-solving model: Dynamic Indicators of Basic Early Literacy Skills. In M. R. Shinn (Ed.), *Advanced applications of curriculum-based measurement* (p. 113–142). New York: Guilford Press.
- Lambert, D. (1992). Zero-inflated Poisson regression, with an application to defects in manufacturing. *Technometrics, 34*, 1–14.
- Little, R. (1988). A test of missing completely at random for multivariate data with missing values. *Journal of the American Statistical Association, 83*, 1198–1202.
- Little, R., & Rubin, D. (1987). *Statistical analysis with missing data*. New York: John Wiley & Sons.
- Lohr, S. (1999). *Sampling: Design and analysis*. New York: Duxbury.
- Luze, G. J., Linebarger, D. L., Greenwood, C. R., Carta, J. J., & Walker, D. (2001). Toward a technology of dynamic indicators of communicative expression for infants and toddlers. *School Psychology Review, 30*, 383–406.
- Marston, D., Muyskens, P., Lau, M., & Canter, A. (2003). Problem-solving model for decision making with high-incidence disabilities: The Minneapolis experience. *Learning Disabilities Research and Practice, 18*, 187–200.
- Marston, D., Pickart, M., Reschly, A., Muyskens, P., Heistad, D., & Tindal, G. (2007). Early literacy measures for improving student reading achievement: Translating research into practice. *Exceptionality, 5*, 97–118.
- McConnell, S. R., McEvoy, M. A., & Priest, J. S. (2002). “Growing” measures for monitoring progress in early childhood education: A research and development proves for Individual Growth and Development Indicators. *Assessment for Effective Intervention, 27*, 3–14.
- McConnell, S. R., Priest, J. S., Davis, S. D., & McEvoy, M. A. (2002). Best practices in measuring growth and development for preschool children. In A. Thomas & J. Grimes (Eds.), *Best practices in school psychology* (4th ed., Vol. 2, pp. 1231–1246). Washington, DC: National Association of School Psychologists.
- McGlinchey, M. T., & Hixson, M. D. (2004). Using curriculum-based measurement to predict performance on state assessments in reading. *School Psychology Review, 33*, 193–203.
- McLachlan, G., & Peel, D. (2000). *Finite mixture models*. New York: John Wiley & Sons.
- Minneapolis Public Schools Content Standards. (n.d.). Retrieved September 9, 2005, from <http://pic.mpls.k12.mn.us/sites/97711090-59b5-4f98964e932ab29cf5be/uploads/progmonitor.pdf>
- Missall, K. N. (2002). Reconceptualizing school adjustment: A search for intervening variables. *Dissertation Abstracts International, 63*(5-A), 1712.
- Missall, K. N., & McConnell, S. R. (2004). *Technical report: Psychometric characteristics of Individual Growth and Development Indicators—Picture naming, rhyming & alliteration*. Minneapolis, MN: Center for Early Education and Development.
- Missall, K. N., McConnell, S. R., & Cadigan, K. (2006). Early literacy development: Skill growth and relations between classroom variables for preschool children. *Journal of Early Intervention, 29*, 1–21.
- Muthen, L., & Muthen, B. (2005). *Mplus® statistical analysis with latent variables: User's guide*. Los Angeles, CA: Muthen & Muthen.
- Muyskens, P., Marston, D., & Reschly, A. (2005). *Behavioral screening for early intervention*. Manuscript submitted for publication.
- National Assessment of Educational Progress. (1999). *Report card for the nation and the states*. Washington, DC: National Center for Educational Statistics.
- National Center for Educational Statistics. (1992). *Executive summary of adult literacy in America: A first look*

- at the results of the national adult literacy survey. Washington, DC: Author.
- No Child Left Behind Act. (2001). Retrieved March 24, 2006, from <http://www.ed.gov/policy/elsec/leg/esea02/107-100.pdf>
- Pre-Elementary Education Longitudinal Study. (2004). Retrieved March 24, 2006, from <http://www.peels.org/Assessments.asp>
- Phaneuf, R. L., & Silbergliitt, B. (2003). Tracking preschoolers' language and pre-literacy development using a general outcome measurement system. *Topics in Early Childhood Special Education, 23*, 114-123.
- Pickart, M., Sheran, C., Betts, J., Heistad, D., & Muyskens, P. (2006). *Minneapolis Kindergarten Assessments: Technical manual*. Minneapolis: Minneapolis Public Schools.
- Priest, J. S., McConnell, S. R., Walker, D., Carta, J. J., Kaminski, R. A., McEvoy, M. A., Good, R., Greenwood, C. R., & Shinn, M. R. (2001). General growth outcomes for young children: Developing a foundation for continuous progress measurement. *Journal of Early Intervention, 24*, 163-180.
- Priest, J. S., McConnell, S. R., McEvoy, M. A., & Shin, J. (2000). *Early Childhood Research Institute on Measuring Growth and Development: Progress in five domains*. Paper presented at the annual conference of the Division for Early Childhood, Council for Exceptional Children, Albuquerque, NM.
- Priest, J. S., Silbergliitt, B., Hall, S., & Estrem, T. L. (2000). *Progress on preschool IGDIs for early literacy*. Presentation at Heartland Area Education Association, Des Moines, IA.
- Puma, M. N., Karweit, N., Price, C., Ricciuti, A., Thompson, W., & Vanden-Kierman, M. (1997). *Prospects: Final report on student outcomes*. Washington, DC: US Department of Education, Planning and Evaluation Services.
- Reschly, D. J. (1988). Special education reform: School psychology revolution. *School Psychology Review, 17*, 459-501.
- Scanlon, D. M., & Vellutino, F. R. (1996). Prerequisite skills, early instruction, and success in first grade reading: Selected results from a longitudinal study. *Mental Retardation and Developmental Disabilities Research Reviews, 2*, 54-64.
- Scarborough, H. S. (2002). Connecting early language and literacy to later reading (dis)abilities: Evidence, theory, and practice. In S. B. Neuman & D. K. Dickinson (Eds.), *Handbook of early literacy research* (pp. 97-110). New York: Guilford Press.
- Shinn, M. R. (1988). The development of curriculum-based local norms for use in special education decision making. *School Psychology Review, 17*, 61-80.
- Shinn, M. R. (Ed.). (1998). *Advanced applications of curriculum-based measurement*. New York: Guilford Press.
- Shinn, M. R., Good, R. H., Knutson, N., Tilly, W. D., & Collins, V. L. (1992). Curriculum-based measurement reading fluency: A confirmatory analysis of its relation to reading. *School Psychology Review, 21*, 459-479.
- Shonkoff, J. P., & Phillips, D. A. (Eds.). (2000). *From neurons to neighborhoods: The science of early childhood development*. Washington, DC: National Academy Press.
- Snow, C. E., Burns, S., & Griffin, P. (Eds.). (1998). *Preventing reading difficulties in young children*. Washington, DC: National Academy Press.
- Stanovich, K. E. (1986). Matthew effects in reading: Some consequences of individual differences in the acquisition of literacy. *Reading Research Quarterly, 21*, 360-406.
- Torgeson, J. K., & Bryant, B. R. (1994). *Test of phonological awareness*. Austin, TX: Pro-Ed.
- Torgeson, J. K. (2002). The prevention of reading difficulties. *Journal of School Psychology, 40*, 7-26.
- U.S. Department of Education. (2004, August). *A synopsis of the 2004 early reading first project grantees* (CFDA #84.359B). Washington, DC: Author.
- Walker, D., Greenwood, C. R., Hart, B., & Carta, J. J. (1994). Prediction of school outcome based on early language production and socioeconomic factors. *Child Development, 65*, 606-621.
- Whitehurst, G. J., & Lonigan, C. J. (1998). Child development and emergent literacy. *Child Development, 69*, 848-872.
- Whitehurst, G. J., & Lonigan, C. J. (2002). Emergent literacy: Development from prereaders to readers. In S. B. Neuman & D. K. Dickinson (Eds.), *Handbook of early literacy research* (pp. 11-29). New York: Guilford Press.
- Yopp, H. K. (1988). The validity and reliability of phonemic awareness tests. *Reading Research Quarterly, 23*, 159-177.
- Zimmerman, I. L., Steiner, V. G., & Pond, R. V. (2002). *Preschool language scale* (4th ed.). San Antonio, TX: The Psychological Corporation.

Date Received: May 11, 2006

Date Accepted: March 16, 2007

Action Editor: John Hintze ■

Kristen N. Missall, PhD, is Assistant Professor at the University of Kentucky. She graduated from the University of Minnesota and completed a two-year postdoctoral experience at the Center for Early Education and Development at the University of Minnesota. She conducts research in the areas of early literacy, social skill development, school adjustment, and general outcome measurement, and has particular interest in the skills and experiences of children transitioning from preschool to kindergarten.

Amy L. Reschly, PhD, is Assistant Professor in the Department of Educational Psychology & Instructional Technology at the University of Georgia. She is a graduate of the University of Minnesota. Her primary research interests are in the areas of student engagement at school and with learning, drop-out prevention, and curriculum-based measurement, particularly in the areas of reading and early literacy.

Joseph Betts, MMIS, PhD, is School Psychologist and Measurement Statistician working with the Center for Cultural Diversity and Minority Education. He specializes in the use of latent trait theory and modern item response models to assess student academic achievement and development. In addition, his research focuses on issues related to measurement with diverse student groups, such as predictive bias and measurement invariance.

David Heistad, PhD, is Executive Director of Research, Evaluation and Assessment for the Minneapolis Public Schools and is a member of the Institute for Education Sciences Urban Education Research Taskforce.

Scott R. McConnell, PhD, is Professor in the Department of Educational Psychology and Director of Community Engagement for the Center for Early Education and Development at the University of Minnesota. He has published articles on the assessment and treatment of social behavior deficits, social competence, school adjustment, and academic performance, including development of early literacy skills.

Mary Pickart is Teacher on Special Assignment in the Research, Evaluation and Assessment Department for the Minneapolis Public Schools. She coordinates the district's kindergarten and first-grade assessments. Her research interests include early literacy and intervention.

Christina P. Sheran earned her PhD in Educational Psychology with a dual major in Early Education Special Education and School Psychology from the University of Minnesota. Currently she works in Research and Evaluation in the Minneapolis Public Schools developing early measures for children age 3 to Grade 3 and training and coaching pre-k teachers in the area of early literacy.

Doug Marston, PhD, NCSP, is the Administrator for Research and Evaluation in Special Education, Minneapolis Public Schools. His research interests include curriculum-based measurement, problem-solving models, and using technology for making data-based education decisions.